



# **CT-400 CHASSIS**

## **THIRTEEN-SLOT VXIBUS CHASSIS**

### **USER'S MANUAL**

**82-0050-000**  
**Rev. March 31, 2003**

**VXI Technology, Inc.**

**2031 Main Street**  
**Irvine, CA 92614-6509**  
**(949) 955-1894**



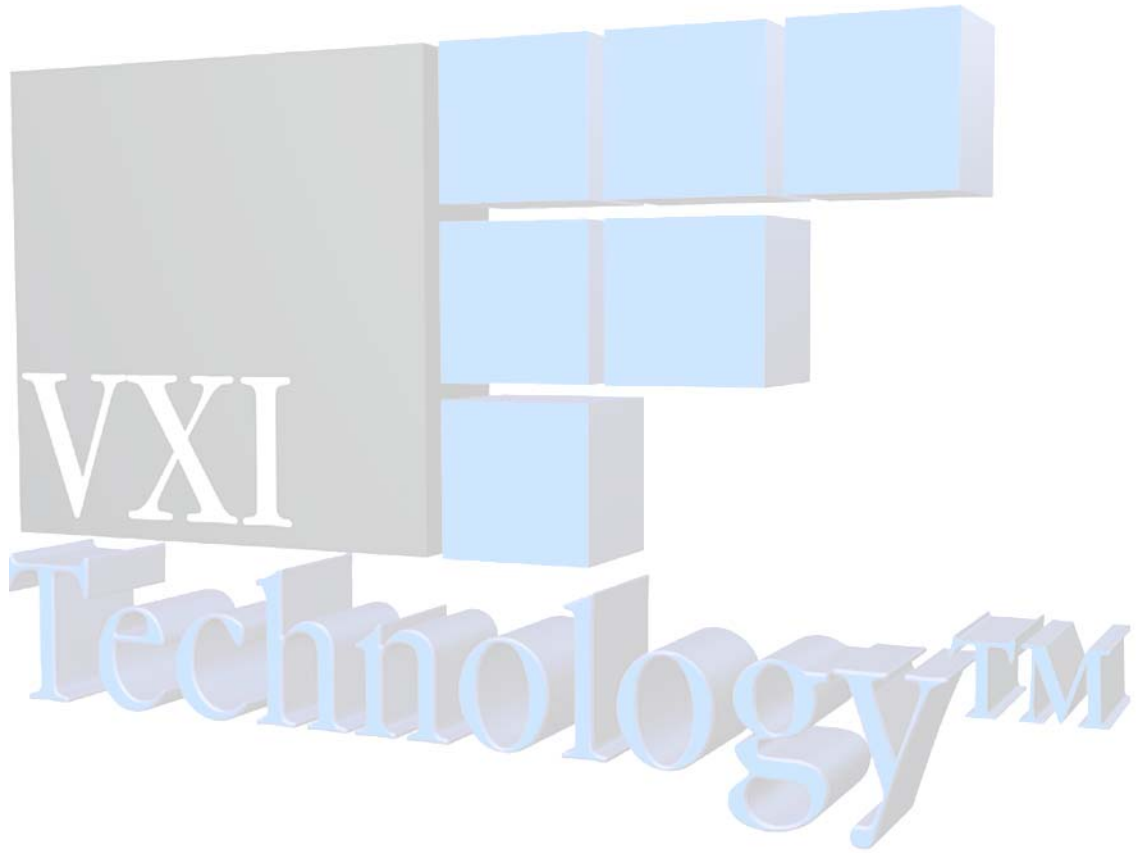

# TABLE OF CONTENTS

## INTRODUCTION

Certification .....	6
Warranty .....	6
Limitation of Warranty .....	6
Restricted Rights Legend .....	6
DECLARATION OF CONFORMITY .....	7
GENERAL SAFETY INSTRUCTIONS.....	8
Terms and Symbols.....	8
Warnings.....	8
SUPPORT RESOURCES .....	11
<b>SECTION 1 .....</b>	<b>13</b>
INTRODUCTION .....	13
Introduction.....	13
General Description .....	14
Power Supplies.....	14
Backplane.....	14
Cooling.....	14
CT-400 Mainframe Features .....	15
Voltage Indicator LEDs .....	16
Rear Panel Monitor / Control Connector .....	17
CT-400 Specifications .....	18
CT-400 Dimensional Diagram.....	20
<b>SECTION 2 .....</b>	<b>27</b>
INSTALLATION .....	27
Introduction.....	27
Power Requirements .....	27
Connecting the Mainframe to Earth Ground.....	28
Air Flow Requirements .....	28
Installing the Card Shield Option.....	29
Installing Blanking Panels .....	29
BENCH-TOP CT-400 USE.....	30
Overview.....	30
RACK MOUNTING THE CT-400 .....	31
Overview.....	31
Assembly Preparation .....	31
Mounting the Mainframe .....	31
Option 100 - Adjustable Rack Mount Flanges with Handles .....	32
Required Tools.....	32
Parts List .....	32
Assembly Procedure .....	32
Option 101 - <i>VXIplug&amp;play</i> Rack Mount Kit .....	34
Required Tools.....	34
Parts List .....	34
Assembly Procedure .....	34
Option 102 - Rack Mount Slides.....	36
Required Tools.....	36
Parts List .....	36
Assembly Procedure .....	36

- ADDITIONAL RACK MOUNT OPTIONS ..... 38
  - Overview ..... 38
  - Option 103 - Transparent Front Door Installation Procedure ..... 40
  - Required Tools ..... 40
  - Parts List ..... 40
  - Assembly Procedure ..... 40
  - Option 104 - Hinged Custom Front Panel Installation Procedure ..... 42
  - Required Tools ..... 42
  - Parts List ..... 42
  - Assembly Procedure ..... 42
  - Option 105/106 - 1U/2U Cable Trays Installation Procedure ..... 44
  - Required Tools ..... 44
  - Parts List ..... 44
  - Assembly Procedure ..... 44
- INSTALLATION OF VXI MODULES ..... 46
  - Overview ..... 46
  - Required Tools ..... 46
  - Installation Procedure ..... 46
- DISCONNECTING THE MAINFRAME ..... 47
- SECTION 3 ..... 49**
  - OPERATION ..... 49
    - Introduction ..... 49
    - CT-400 Monitor Board ..... 50
    - CT-400 Monitor Board - Signals ..... 51
- SECTION 4 ..... 53**
  - SERVICE INFORMATION ..... 53
    - Introduction ..... 53
    - Cleaning the Air Filters ..... 54
    - Power Supply Replacement Procedure ..... 56
- SECTION 5 ..... 57**
  - DOCUMENTATION ..... 57
    - Introduction ..... 57
- INDEX ..... 58**



## **CERTIFICATION**

VXI Technology, Inc. (VTI) certifies that this product met its published specifications at the time of shipment from the factory. VTI further certifies that its calibration measurements are traceable to the United States National Institute of Standards and Technology (formerly National Bureau of Standards), to the extent allowed by that organization's calibration facility, and to the calibration facilities of other International Standards Organization members.

## **WARRANTY**

The product referred to herein is warranted against defects in material and workmanship for a period of three years from the receipt date of the product at customer's facility. The sole and exclusive remedy for breach of any warranty concerning these goods shall be repair or replacement of defective parts, or a refund of the purchase price, to be determined at the option of VTI.

For warranty service or repair, this product must be returned to a VXI Technology authorized service center. The product shall be shipped prepaid to VTI and VTI shall prepay all returns of the product to the buyer. However, the buyer shall pay all shipping charges, duties, and taxes for products returned to VTI from another country.

VTI warrants that its software and firmware designated by VTI for use with a product will execute its programming when properly installed on that product. VTI does not however warrant that the operation of the product, or software or firmware will be uninterrupted or error free.

## **LIMITATION OF WARRANTY**

The warranty shall not apply to defects resulting from improper or inadequate maintenance by the buyer, buyer-supplied products or interfacing, unauthorized modification or misuse, operation outside the environmental specifications for the product, or improper site preparation or maintenance.

VXI Technology, Inc. shall not be liable for injury to property other than the goods themselves. Other than the limited warranty stated above, VXI Technology, Inc. makes no other warranties, express or implied, with respect to the quality of product beyond the description of the goods on the face of the contract. VTI specifically disclaims the implied warranties of merchantability and fitness for a particular purpose.

## **RESTRICTED RIGHTS LEGEND**

Use, duplication, or disclosure by the Government is subject to restrictions as set forth in subdivision (b)(3)(ii) of the Rights in Technical Data and Computer Software clause in DFARS 252.227-7013.

VXI Technology, Inc.  
2031 Main Street  
Irvine, CA 92614-6509 U.S.A.

# DECLARATION OF CONFORMITY

Declaration of Conformity According to ISO/IEC Guide 22 and EN 45014

<b>MANUFACTURER'S NAME</b>	VXI Technology, Inc.
<b>MANUFACTURER'S ADDRESS</b>	2031 Main Street Irvine, California 92614-6509
<b>PRODUCT NAME</b>	Thirteen-Slot VXIbus Chassis
<b>MODEL NUMBER(S)</b>	CT-400
<b>PRODUCT OPTIONS</b>	All
<b>PRODUCT CONFIGURATIONS</b>	All

*VXI Technology, Inc. declares that the aforementioned product conforms to the requirements of the Low Voltage Directive 73/23/EEC and the EMC Directive 89/366/EEC (inclusive 93/68/EEC) and carries the "CE" mark accordingly. The product has been designed and manufactured according to the following specifications:*

<b>SAFETY</b>	EN61010 (2001)
<b>EMC</b>	EN61326 (1997 w/A1:98) Class A CISPR 22 (1997) Class A VCCI (April 2000) Class A ICES-003 Class A (ANSI C63.4 1992) AS/NZS 3548 (w/A1 & A2:97) Class A FCC Part 15 Subpart B Class A EN 61010-1:2001

*I hereby declare that the aforementioned product has been designed to be in compliance with the relevant sections of the specifications listed above as well as complying with all essential requirements of the Low Voltage Directive.*

**March 2003**



  
**Jerry Patton, QA Manager**

---

## GENERAL SAFETY INSTRUCTIONS

---

Review the following safety precautions to avoid bodily injury and/or damage to the product. These precautions must be observed during all phases of operation or service of this product. Failure to comply with these precautions, or with specific warnings elsewhere in this manual, violates safety standards of design, manufacture, and intended use of the product.

*Service should only be performed by qualified personnel.*

### TERMS AND SYMBOLS

These terms may appear in this manual:



Indicates that a specific **WARNING** or **CAUTION** follows.

**WARNING** Indicates that a procedure or condition may cause bodily injury or death.

**CAUTION** Indicates that a procedure or condition could possibly cause damage to equipment or loss of data.

These symbols may appear on the product:

**WARNING** Indicates that a procedure or condition may cause bodily injury or death.



**ATTENTION** - Important safety instructions



Frame or chassis ground



Alternating Current (AC)

### WARNINGS

Follow these precautions to avoid injury or damage to the product:

**Use Proper Power Cord** To avoid hazard, only use the power cord specified for this product.

**Use Proper Power Source** To avoid electrical overload, electric shock, or fire hazard, do not use a power source that applies other than the specified voltage.



## WARNINGS (CONT.)

### Use Proper Fuse

To avoid fire hazard, only use the type and rating fuse specified for this product.

### Avoid Electric Shock

To avoid electric shock or fire hazard, do not operate this product with the covers removed. Do not connect or disconnect any cable, probes, test leads, etc. while they are connected to a voltage source. Remove all power and unplug unit before performing any service. ***Service should only be performed by qualified personnel.***

### Ground the Product

This product is grounded through the grounding conductor of the power cord. To avoid electric shock, the grounding conductor must be connected to earth ground.

### Operating Conditions

To avoid injury, electric shock or fire hazard:

- Do not operate in wet or damp conditions.
- Do not operate in an explosive atmosphere.
- Operate or store only in specified temperature range.
- Provide proper clearance for product ventilation to prevent overheating.
- DO NOT operate if you suspect there is any damage to this product. ***Product should be inspected or serviced only by qualified personnel.***



### Improper Use

The operator of this instrument is advised that if the equipment is used in a manner not specified in this manual, the protection provided by the equipment may be impaired. Conformity is checked by inspection.



---

## SUPPORT RESOURCES

---

Support resources for this product are available on the Internet and at VXI Technology customer support centers.

### Internet Support

E-mail: [support@vxitech.com](mailto:support@vxitech.com)

Web Address: <http://www.vxitech.com>

### Telephone Support (U.S.)

Tel: (949) 955-1894 **West Coast**  
(216) 447-8950 **East Coast**

Fax: (949) 955-3041 **West Coast**  
(216) 447-8951 **East Coast**

### VXI Technology Headquarters

Technical Support  
VXI Technology, Inc.  
2031 Main Street  
Irvine, CA 92614-6509

Tel: (949) 955-1894  
Fax: (949) 955-3041





# SECTION 1

---

## INTRODUCTION

---

### INTRODUCTION

This section contains a general description of operating features of the CT-400. A list of mainframe features follows the description, which is then followed by a brief discussion of the options available for the CT-400.



**FIGURE 1-1 CT-400 THIRTEEN-SLOT MAINFRAME WITH MODULES**

## GENERAL DESCRIPTION

The CT-400 mainframe is a C-size, thirteen-slot, VXIbus compatible mainframe that conforms fully to VXIbus Specification Revision 1.4. The mainframe employs a multi-layer backplane to ensure premium VXIbus and VMEbus performance and provides all power supplies required by the VXIbus specification.

The CT-400 mainframe contains thirteen slots in the card cage, twelve of which are available for use by VXIbus compatible instruments. The thirteenth slot in the card cage (slot 0) is typically dedicated to the VXIbus Resource Manager.

## POWER SUPPLIES

The CT-400 is designed to operate at line frequencies from 47 to 440 Hz and is factory preset to operate at a nominal line voltage of 115 VAC. The AC input is both auto-voltage and auto-frequency ranging and may be reconfigured to operate at a nominal 220 VAC by simply changing the fuse located at the rear of the chassis.

The power supply assembly is completely removable from the rear of the mainframe. The assembly is short-circuit, over-voltage, reverse-voltage and thermal-shutdown protected. In addition, all supply lines are monitored and displayed on the front panel to provide user-feedback of correct operation.

## BACKPLANE

The CT-400 has a jumperless auto-configurable backplane with automatic bus grant and IACK jumpering. There is also a custom power sub-panel to distribute all the supply lines across the backplane, as well as a 10-layer stripline construction that minimizes crosstalk.

## COOLING

The airflow design uses a pressurized plenum system with a baffling system to guarantee enough cooling capacity. The cooling direction for the VXI instruments is air is drawn through the back of the mainframe and exhausted out both sides at the top. The power supply is cooled by an airflow that moves from left (if facing the mainframe) to right.

## CT-400 MAINFRAME FEATURES

FRONT PANEL FEATURES	
<b>POWER SWITCH</b>	
<b>Feature 1</b>	When elevated, the mainframe is in standby mode, where power is supplied to the mainframe, but not to the VXI modules. When depressed, power is supplied to both mainframe and VXI modules.
<b>VOLTAGE MONITOR INDICATORS</b>	
<b>Feature 2</b>	Indicates whether specific backplane voltages are within specifications. See Figure 1-3 for details.
REAR PANEL FEATURES	
<b>MODULE FAN FILTER</b>	
<b>Feature 3</b>	Replaceable component that filters the air that cools the plug-in modules.
<b>CHASSIS GROUND TERMINAL</b>	
<b>Feature 4</b>	Used to electrical ground the mainframe.
<b>J200 CONNECTOR</b>	
<b>Feature 5</b>	AC power receptacle.
<b>F200 CONNECTOR</b>	
<b>Feature 6</b>	Fuse location.
<b>J210 CONNECTOR</b>	
<b>Feature 7</b>	Monitor / Control Connector.
<b>POWER SUPPLY FAN FILTER</b>	
<b>Feature 8</b>	Replaceable component that filters the air that cools the power supply.
<b>MONITOR BOARD / J211 CONNECTOR</b>	
<b>Feature 9</b>	Provides monitoring of the mainframe's operation and environment. (See Section 3 for more details.)
<b>POWER SUPPLY</b>	
<b>Feature 10</b>	Replaceable power supply unit.

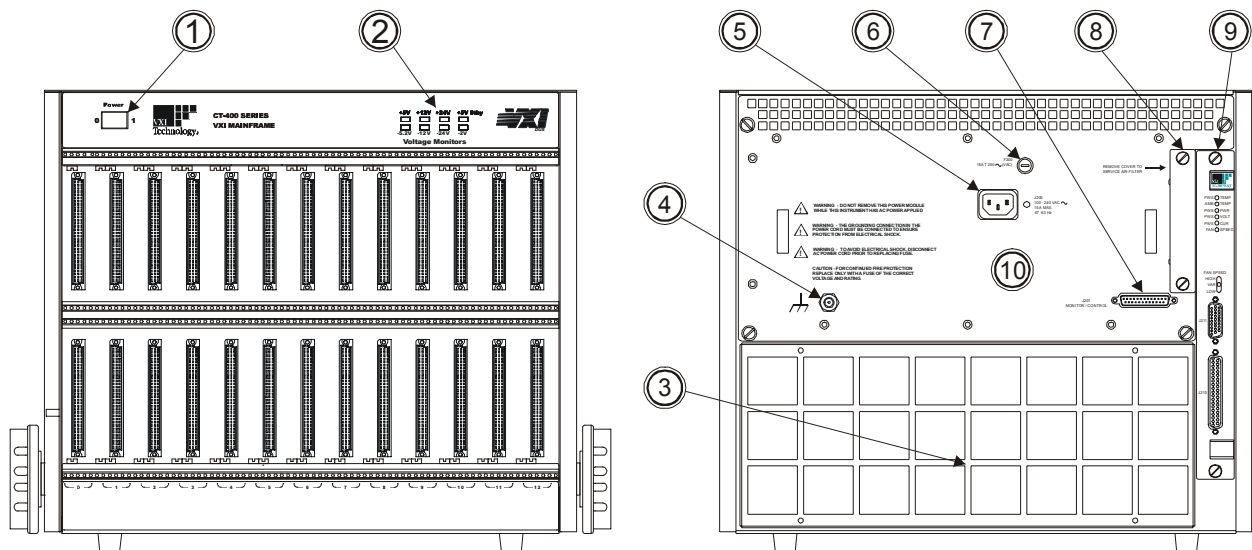

**FIGURE 1-2 MAINFRAME FEATURE LOCATIONS**

## VOLTAGE INDICATOR LEDs

The power supply lines are monitored and displayed on the front panel, providing information pertaining to the chassis operational status.

### Voltage Monitor LEDs

Green : Within Voltage Specifications  
 Not Lit : Under Voltage  
 Red : Over Voltage

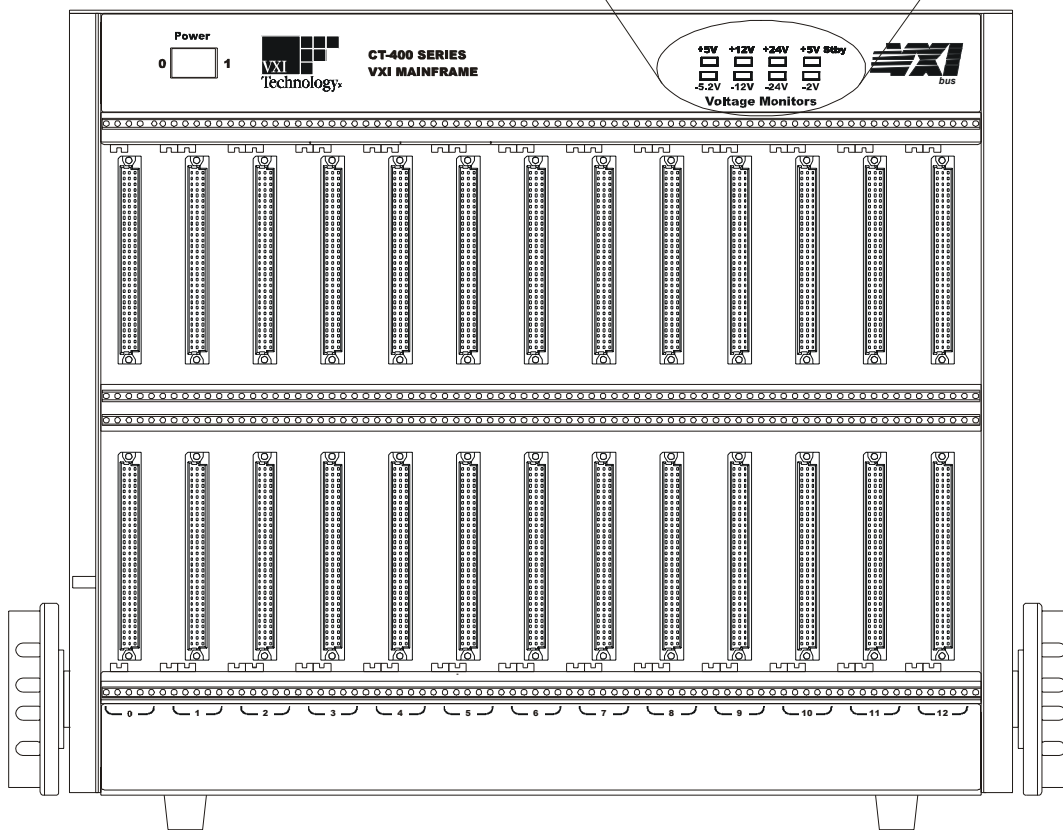
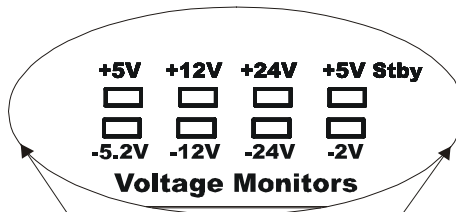

FIGURE 1-3 FRONT PANEL VOLTAGE INDICATORS



## REAR PANEL MONITOR / CONTROL CONNECTOR

The 25-pin Monitor / Control Connector (see Figure 1-2) provides access to the backplane voltages and other signals. The following table shows a pinout/signal list along with a brief description of each. Refer to the pin locations in Figure 1-4.

**TABLE 1-1 MONITOR / CONTROL CONNECTOR PINOUT ASSIGNMENTS**

PIN	SIGNAL	DESCRIPTION
1	-24 VMON	VXibus Voltage Monitor Output
2	GND	Logic Ground
3	-2 VMON	VXibus Voltage Monitor Output
4	GND	Logic Ground
5	+24 IMON	Power Supply Current Monitor Output
6	-12 IMON	Power Supply Current Monitor Output
7	-2 IMON	Power Supply Current Monitor Output
8	-5.2 VMON	VXibus Voltage Monitor Output
9	RSV	Reserved
10	+5 STANDBY	VXibus +5 V Standby Input
11	+5 VMON	VXibus Voltage Monitor Output
12	ACFAIL*	VXibus ACFAIL* Input or Monitor Output (see note)
13	RSV	Reserved
14	GND	Logic Ground
15	-12 VMON	VXibus Voltage Monitor Output
16	+24 VMON	VXibus Voltage Monitor Output
17	+12 VMON	VXibus Voltage Monitor Output
18	+12 IMON	Power Supply Current Monitor Output
19	-24 IMON	Power Supply Current Monitor Output
20	-5.2 IMON	Power Supply Current Monitor Output
21	+5 IMON	Power Supply Current Monitor Output
22	+5 STANDBY	VXibus +5 V Standby Input
23	R INHIBIT*	Power Supply Remote Inhibit Input
24	GND	Logic Ground
25	SYSRESET*	VXibus SYSRESET* Input or Monitor Output (see note)

**NOTE** Refer to VXibus and VMEbus specifications for details on using the ACFAIL\* and SYSRESET\* signals

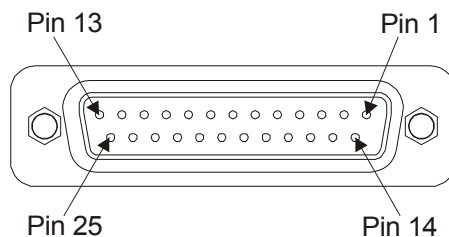

**FIGURE 1-4 DETAIL - MONITOR / CONTROL CONNECTOR PIN LOCATIONS**

**CT-400 SPECIFICATIONS**

<b>GENERAL SPECIFICATIONS</b>	
<b>SIZE</b>	16.7" (424.18 mm) W x 14.00" (355.60 mm) H x 25.00" D (635.00 mm) Thirteen C-size VXIbus card slots
<b>WEIGHT</b>	< 50 lb (11.3 kg)
<b>VXIbus VERSION</b>	1.4
<b>MTBF</b>	100,000 hr
<b>MTTR</b>	5 min
<b>ENVIRONMENTAL SPECIFICATIONS</b>	
<b>OPERATING LOCATION</b>	This chassis should be operated indoors in a controlled environment, protected from exposure to the elements (i.e. direct sunlight, precipitation, wind, etc.)
<b>TEMPERATURE</b>	
<b>Operating</b>	0°C to +50°C
<b>Storage</b>	-40°C to +70°C
<b>HUMIDITY</b>	5 - 95% (non-condensing)
<b>COOLING SPECIFICATIONS</b>	
<b>COOLING REQUIREMENTS</b>	> 100 W/slot
<b>COOLING MODES</b>	Three cooling modes are available for the CT-400 mainframe. High or low speed cooling modes can be selected by moving the Fan Speed switch at the rear of the mainframe. The variable cooling speed mode determines fan speed as a function of ambient temperature a mainframe load. The power supply and modules are cooled by separate fans.
<b>AIR FLOW PATH</b>	Air is drawn into the mainframe from the rear and is pressurized below the cards. The air is then distributed across all slots along the total length of each slot and is exhausted through the top of the mainframe. When the mainframe is rack mounted, allow approximately 2.0 inches (5.1 cm) of clearance at the top and rear for proper airflow.

**POWER SPECIFICATIONS****POWER**

<b>Available</b>	1630 W
<b>Useable</b>	1000 W

**DC SUPPLY VOLTAGE**

A total of 1000 W may be supplied to the modules with the following maximum currents (1800 W version available):

Voltage	Peak Current ( $I_{MP}$ )	Dynamic Current ( $I_{MD}$ )
+5 V	80 A	15 A
-5.2 V	60 A	10 A
-2 V	30 A	5 A
+12 V	12 A	3 A
-12 V	12 A	3 A
+24 V	12 A	4 A
-24 V	12 A	4 A

**OUTPUT VOLTAGE**

Voltage	Allowed Variation	Ripple/Noise DC Load	Induced Ripple Noise
+5 V	+0.25 V / -0.125 V	50 mV	50 mV
-5.2 V	-0.26 V / +0.125 V	50 mV	50 mV
-2 V	-0.10 V / +0.72 V	50 mV	50 mV
+12 V	+0.60 V / +0.36 V	50 mV	50 mV
-12 V	-0.60 V / +0.36 V	50 mV	50 mV
+24 V	+1.20 V / -0.72 V	150 mV	150 mV
-24 V	-1.20 V / +0.74 V	150 mV	150 mV

**POWER INPUT**

<b>Input Voltage</b>	
<b>Nominal AC</b>	100 VAC min. - 240 VAC max.
<b>Nominal DC</b>	120 - 350 VDC
<b>Frequency</b>	47 Hz - 63 Hz (47 - 440 Hz with increased leakage current and reduced PFC)
<b>Inrush Current</b>	< 70 A (cold start or after 1 minute cool down)
<b>Input Power</b>	1000 W max
<b>Input Leakage</b>	< 1.24 MA @ 264 VAC, 53 Hz
<b>Input Harmonics</b>	Meets EN61000-3-2
<b>Fuse</b>	
<b>90 – 250 V Operation</b>	15 A, 250 V, slow blow
<b>207 – 250 V Operation</b>	10 A, 250 V, slow blow

**PERIODIC AND RANDOM DEVIATIONS**

<b>±24 V</b>	150 mV <sub>P-P</sub>
<b>All Others</b>	50 mV <sub>P-P</sub>

**AUXILIARY DC OUTPUTS**

1.5 A each at all seven supply voltages (fused/self-healing)

**POWER SUPPLY**

UL, CSA, TUV approved  
Shout circuit, over-voltage, reverse voltage and thermal shutdown protection

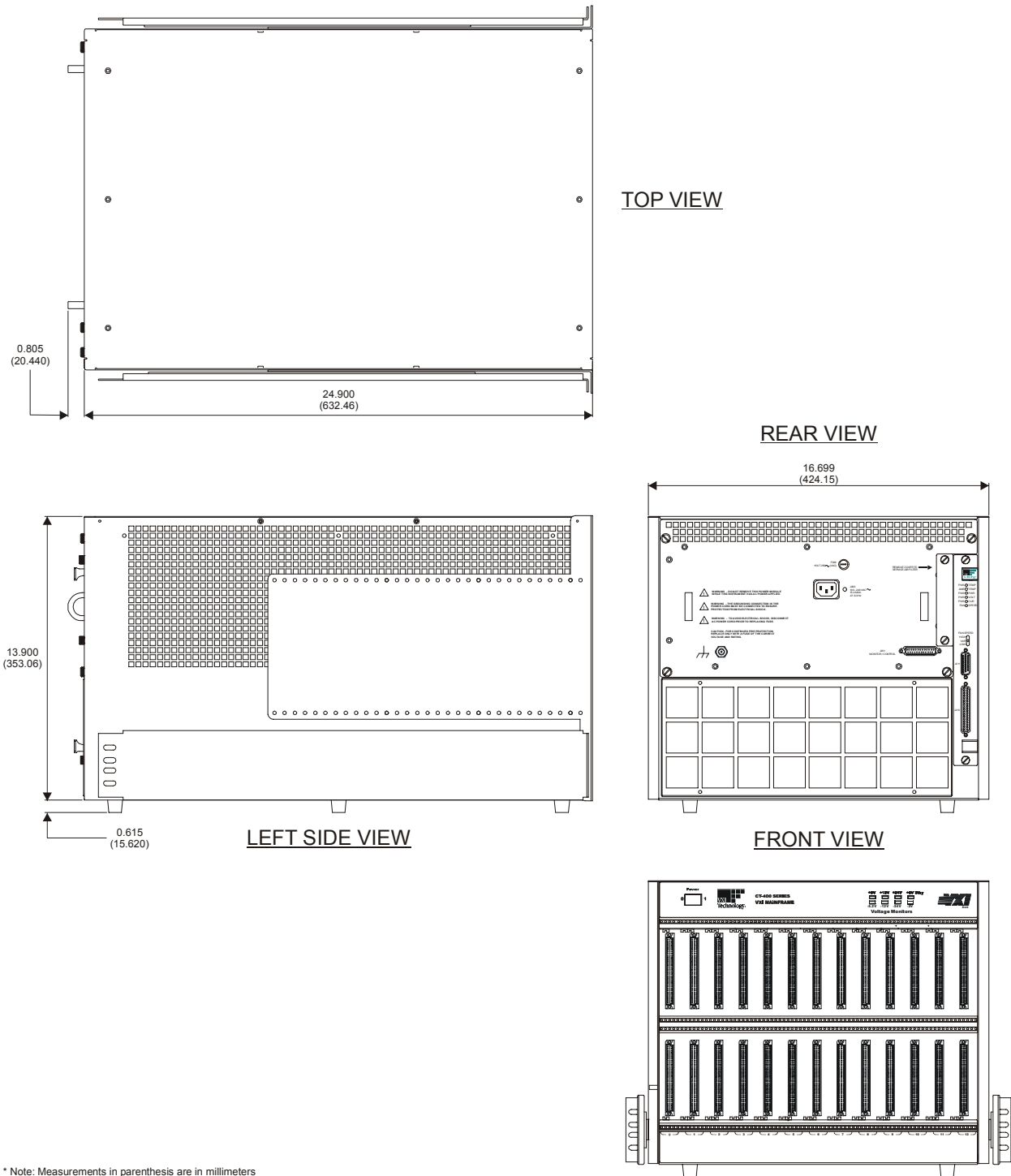

**FIGURE 1-5 CT-400 DIMENSIONAL DIAGRAM**

**TABLE 1-3 CT-400 OPTIONS**

<b>OPTIONS</b>	
<b>ADJUSTABLE RACK MOUNT FLANGES WITH HANDLES</b>	
<b>OPTION 100</b>	These allow the mainframe to be accommodated into any depth rack - either recessed in the rack up to 10 inches (25.4 cm) or extended out from the rack up to 5 inches (12.7 cm).
<b>VXIPLUG&amp;PLAY RACK MOUNT KIT</b>	
<b>OPTION 101</b>	This allows the CT-400 to be used with VXI <i>plug&amp;play</i> adapters and interfaces.
<b>RACK MOUNT SLIDES</b>	
<b>OPTION 102</b>	Mounts the CT-400 in the rack while allowing access by sliding the unit.
<b>TRANSPARENT FRONT DOOR</b>	
<b>OPTION 103</b>	Protects the instrumentation and cabling while allowing viewing of the VXIbus instrument annunciators.
<b>HINGED CUSTOM FRONT PANEL</b>	
<b>OPTION 104</b>	A customizable front panel is available that hinges down and mounts to the front of the CT-400. This option allows custom connectors and small interface adapters to be mounted directly to the front of the VXIbus mainframe; reducing cable lengths and improving signal integrity (see Figure 1-9 for an example).
<b>1U CABLE TRAY</b>	
<b>OPTION 105</b>	A 1U Cable tray that allows access between the front and rear of the mainframe and other instruments within the rack.
<b>2U CABLE TRAY</b>	
<b>OPTION 106</b>	A 2U Cable tray that allows access between the front and rear of the mainframe and other instruments within the rack.
<b>BACK PLANE SHIELDS</b>	
<b>OPTION 107</b>	Backplane shields improve EMI/RFI performance.
<b>INTERMODULE SHIELDS (12)</b>	
<b>OPTION 108</b>	Intermodule shields improve EMI/RFI performance.



**FIGURE 1-6 OPTIONS 100 & 106 - MOUNTING FLANGES/HANDLES & 2U CABLE TRAY**



**FIGURE 1-7 OPTION 106 – 2U CABLE TRAY – REAR VIEW**



**FIGURE 1-8 OPTIONS 100, 103 & 106 - MOUNTING FLANGES/HANDLES, 2U CABLE TRAY & DOOR**





**FIGURE 1-9 OPTION 104 - HINGED CUSTOM FRONT PANEL**



# SECTION 2

---

## INSTALLATION

---

### INTRODUCTION

This section includes instructions on CT-400 configuration and installation. When the CT-400 is unpacked from its shipping carton, the contents should include the following items:

- (1) CT-400 Thirteen-Slot Mainframe
- (1) CT-400 User's Manual (this manual)
- (1) Power cord

All components should be immediately inspected for damage upon receipt of the unit.



**The power cord is the only way to disconnect the CT-400 mainframe from AC power. Therefore, the power cord must be accessible to the operator at all times. When the CT-400 mainframe is mounted in a system rack, the power cord need not be accessible since the rack must have its own disconnect device.**

---

### POWER REQUIREMENTS

The CT-400 is equipped with auto-ranging power supplies, which automatically sense the line power value and set themselves accordingly. No voltage switch selection is required. When the CT-400 is shipped, it is configured for a nominal line voltage of 115 VAC, with a 250 V, 15 A fuse installed. Fuse ratings are as follows:

90 V - 250 V Operation	15 A, 250 V, Slow Blow
207 V - 250 V Operation	10 A, 250 V, Slow Blow



**Do not attempt to change the fuse with the line cord connected. Ensure power is off and the unit is unplugged before changing the fuse.**

---

Refer to Figure 2-1 for the location of the fuse on the back panel.

## CONNECTING THE MAINFRAME TO EARTH GROUND

The CT-400 is configured at the factory for 115 VAC, 60 Hz. The supplied power cord grounding conductor provides adequate grounding for this voltage and frequency level. However, if the CT-400 is to run at anything higher than 63 Hz, the mainframe **MUST** be connected to earth ground at the mainframe as follows:

1. Connect a 16 AWG (or larger) wire to the ground terminal located on the rear panel (this connection is marked by a symbol). Use a grounding lug with a star washer or a toothed lug, to make this connection. See Figure 2-1.
2. Attach the other end of the wire to a permanent earth ground also using a star washer or a toothed lug.



**To avoid electrical shock, the mainframe ground terminal **MUST** be connected to earth ground for frequencies higher than 63 Hz.**

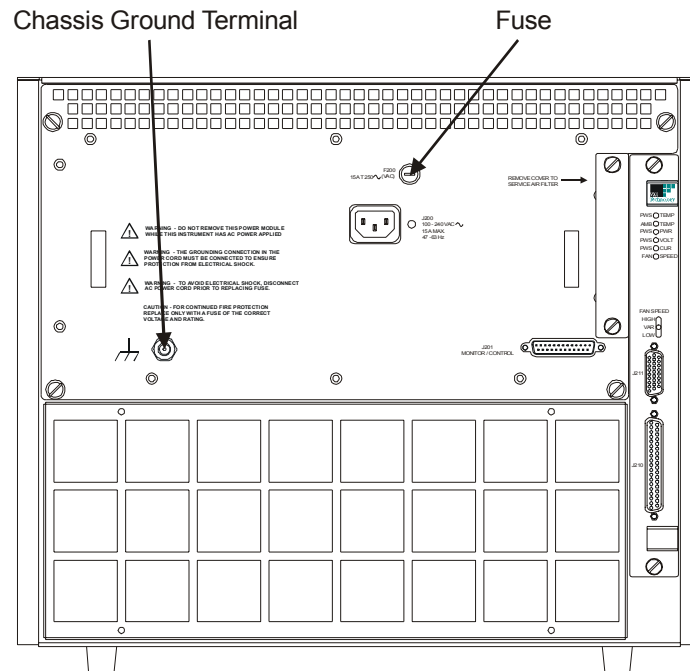

**FIGURE 2-1 FUSE AND GROUND LOCATION**

## AIR FLOW REQUIREMENTS

The CT-400 must be positioned to provide adequate airflow through the unit. Whether used as a bench-top or rack mount unit, provide at least a one inch clearance, at the back and sides, to allow for adequate airflow. Two air filters are installed in the mainframe at the factory, one for the power supply fan (right side from rear view) and a larger one for the mainframe fans (in the rear at the bottom). These filters may be removed if additional airflow is required, but only if the air is filtered at another source within the rack or if it is installed in a clean environment.

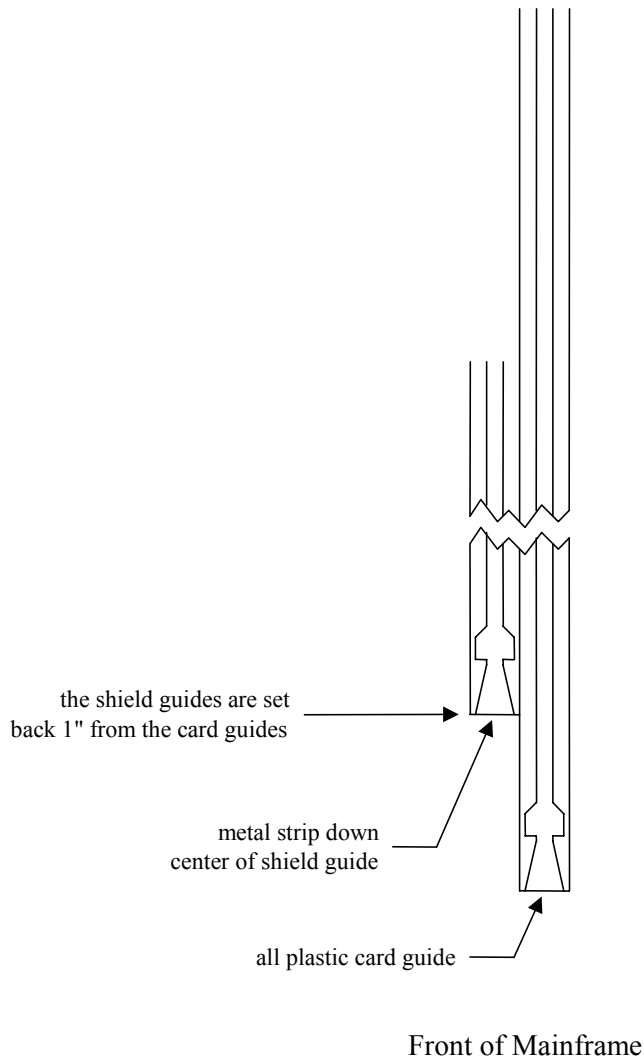

**FIGURE 2-2 DETAIL - CARD GUIDE / SHIELD GUIDE**

### **INSTALLING THE CARD SHIELD OPTION**

Optional card shields are available for improved EMI/RFI performance (see the CT-400 Options table). Each card shield option is installed in the shorter card shield guide, to the left of each card guide. Simply slide the shield into the desired position and then push it backward, towards the backplane, until the flange on the card shield comes to rest against the front of the shield guide.

### **INSTALLING BLANKING PANELS**

To optimize airflow and cooling performance, install optional blank panels (VTI P/N: 41-000-007) into any empty slots. Secure with two captive mounting screws.

---

## **BENCH-TOP CT-400 USE**

---

### **OVERVIEW**

If the CT-400 is to be used as a bench-top mainframe, ensure that adequate spacing is provided for the mainframe for cooling purposes as delineated in the previous section. The mainframe should be placed in a climate-controlled area, away from such elements as precipitation, direct sunlight, etc.

Once installed, the mainframe is not intended to be mobile. If the mainframe must be relocated, remove all externally connected cables along with the power cord from the mainframe. Two people are needed to safely move the mainframe to the newly desired location.

---

# RACK MOUNTING THE CT-400

---

## OVERVIEW

This section contains instructions for installing the different rack mount options available for the CT-400 mainframe. After installation of the rack mount options, the mainframe can then be mounted into an EIA rack. Three different rack mounting options exist for the CT-400 and are listed below.

### *Option 100 - Adjustable Rack Mount Flanges with Handles*

---

The adjustable rack mount flanges with handles will allow for installation of the CT-400 into any size rack – either recessed in the rack up to 10 inches or extended from the rack up to five inches.

### *Option 101 - VXIplug&play (VPP-\*) Rack Mount Kit*

---

The VXIplug&play rack mount kit allows for the easy installation of VXIplug&play adapters and interfaces.

### *Option 102 - Rack Mount Slides*

---

Rack mount slides allow the end user to access the CT-400 while it is mounted in a rack.

## ASSEMBLY PREPARATION

Prior to installation, it is recommended that the positioning of the unit in the rack be planned. Do this by using the rack mount flanges provided as a guide. Place the guides in the desired location of installation, with the flange holes in line with the “center” holes on the rack’s vertical rail. Mark this position for reference.

Support rails, provided with the rack or from some other source, are **required** for the installation of the CT-400. Position the support rail just below the bottom of the mounting flange. When properly installed, the horizontal surface of the support rail should be in line with the bottom of the flange’s mounting location.



**DO NOT mount the mainframe in the rack using only the mounting flanges. Support rails MUST be used in combination with the mounting flanges for support.**

---

## MOUNTING THE MAINFRAME

After installing any of the rack mount options, it is important that, when mounting the mainframe, **two** people (or a mechanical lift) are used to move the mainframe. To mount the mainframe, first remove the four feet from the bottom of the mainframe. Then, using **two** people, position the mainframe onto the previously installed support rails. Slide the mainframe back until the flanges are against the vertical rails in the rack. The mainframe is then secured to the rack’s vertical rails through the mounting holes in either of the rack mounting options.



**To prevent injury when rack-mounting the mainframe, the mainframe should be empty and two people should lift the mainframe into position in the rack.**

---

## **OPTION 100 - ADJUSTABLE RACK MOUNT FLANGES WITH HANDLES**

This procedure provides the necessary instructions for installing the adjustable rack mount flanges with handles.

### **REQUIRED TOOLS**

1. #2 Phillips Screwdriver
2. T15 Torx<sup>®</sup> screwdriver

### **PARTS LIST**

<b>QTY</b>	<b>ITEM</b>	<b>VTI P/N</b>
12	Screw, 8-32 x 5/8" Button Head Torx, Black Steel	37-0130-062
1	Rack Mount Bracket, Standard, Left Side	41-0221-000
1	Rack Mount Bracket, Standard, Right Side	41-0221-001
4	Screw, 8-32 x 3/8" Flat Head Phillips, Zinc	37-0080-037
2	Handle, Chassis, 1 9/32" x 4", Black Aluminum	37-0134-000

### **ASSEMBLY PROCEDURE**

1. Lay the mainframe on a protected work surface on its long side with the voltage monitor LEDs of the mainframe facing front with the power switch toward the top.
2. Locate the right and left side rack mount brackets. Install the rack mount brackets using twelve 8-32 x 5/8" button head Torx screws. Refer to Figure 2-3 for guidance. Depending on how the rack mount brackets are installed, the mainframe can be recessed up to 10" or can be extended from the rack up to 5".
3. Locate the handles for the rack mount brackets. Use the 8-32 x 3/8" flat head Phillips screws to install these handles as shown in Figure 2-3.



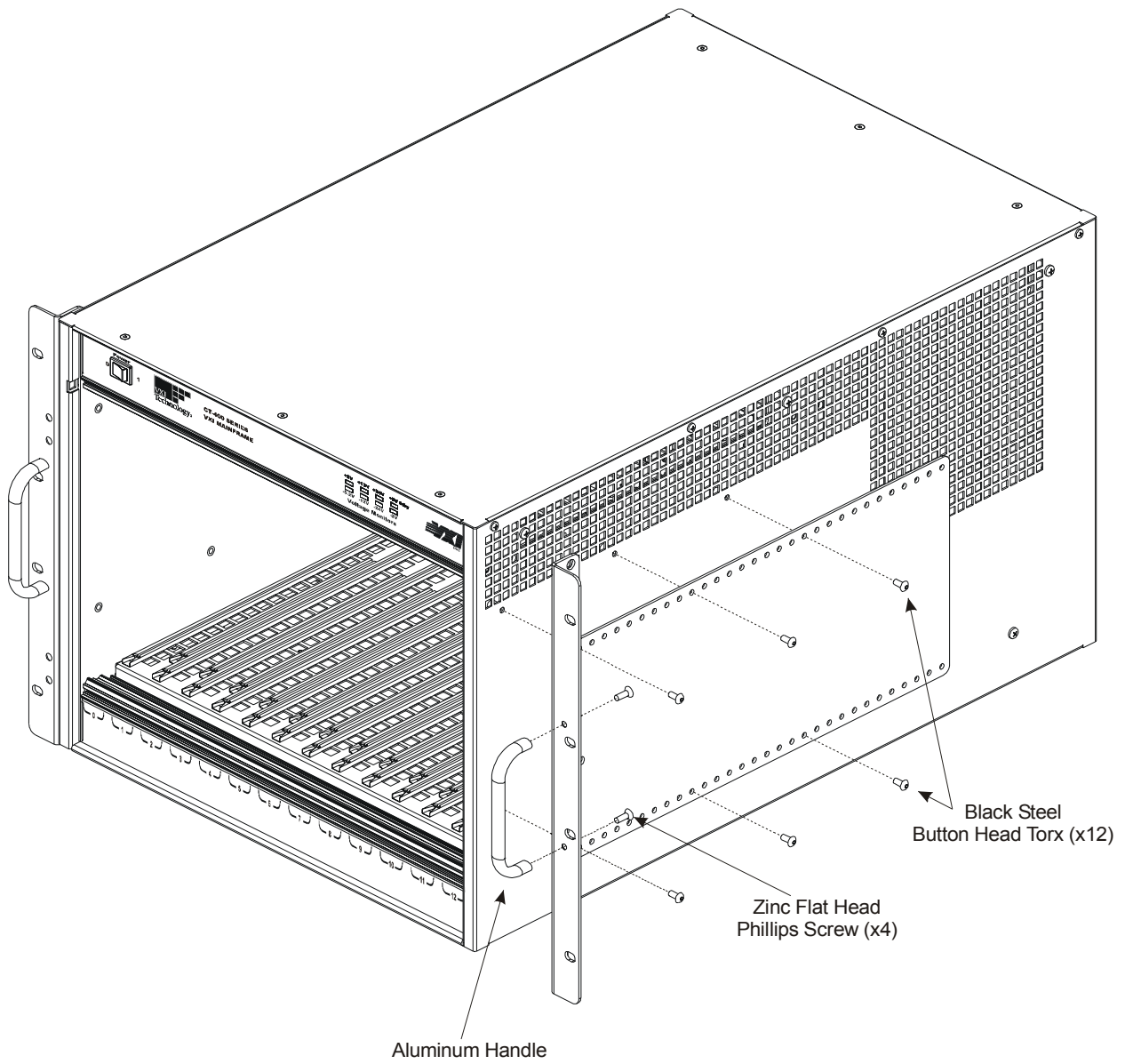

**FIGURE 2-3 ADJUSTABLE RACK MOUNT FLANGE INSTALLATION DIAGRAM**

## **OPTION 101 - VXIPLUG&PLAY RACK MOUNT KIT**

This procedure provides the necessary instructions for installing a VXI*plug&play* rack mount kit.

### **REQUIRED TOOLS**

1. #2 Phillips Screwdriver
2. T15 Torx screwdriver

### **PARTS LIST**

<b>QTY</b>	<b>ITEM</b>	<b>VTI P/N</b>
8	Screw, 8-32 x 5/8" Button Head Torx, Black Steel	37-0130-062
1	Rack Mount Bracket, <i>Plug&amp;Play</i> , Right Side	41-0223-000
1	Rack Mount Bracket, <i>Plug&amp;Play</i> , Left Side	41-0223-001
4	Screw, 10-32 x 7/8", Flat Head Phillips, 82 Deg, Stainless	37-0147-087

### **ASSEMBLY PROCEDURE**

1. Lay the mainframe on a protected work surface on its long side with the voltage monitor LEDs of the mainframe facing front with the power switch toward the top.
2. Locate the right and left side rack mount brackets. Install the rack mount brackets using eight 8-32 x 5/8" button head Torx screws. Refer to Figure 2-4 for guidance. The VXI*plug&play* mounting holes must be aligned where all three mounting holes are directly over the holes on the vertical rails of the rack. In addition, the VXI*plug&play* mounting flanges should cover exactly nine full EIA rack units.
3. Once the rack mount kit has been installed, the mounting receptacle can be installed. Please refer to the instructions provided with the mounting receptacle for assistance in its installation. This hardware is not provided with Option 101. The 10-32 x 7/8" flat head Phillips screws are provided for this purpose.

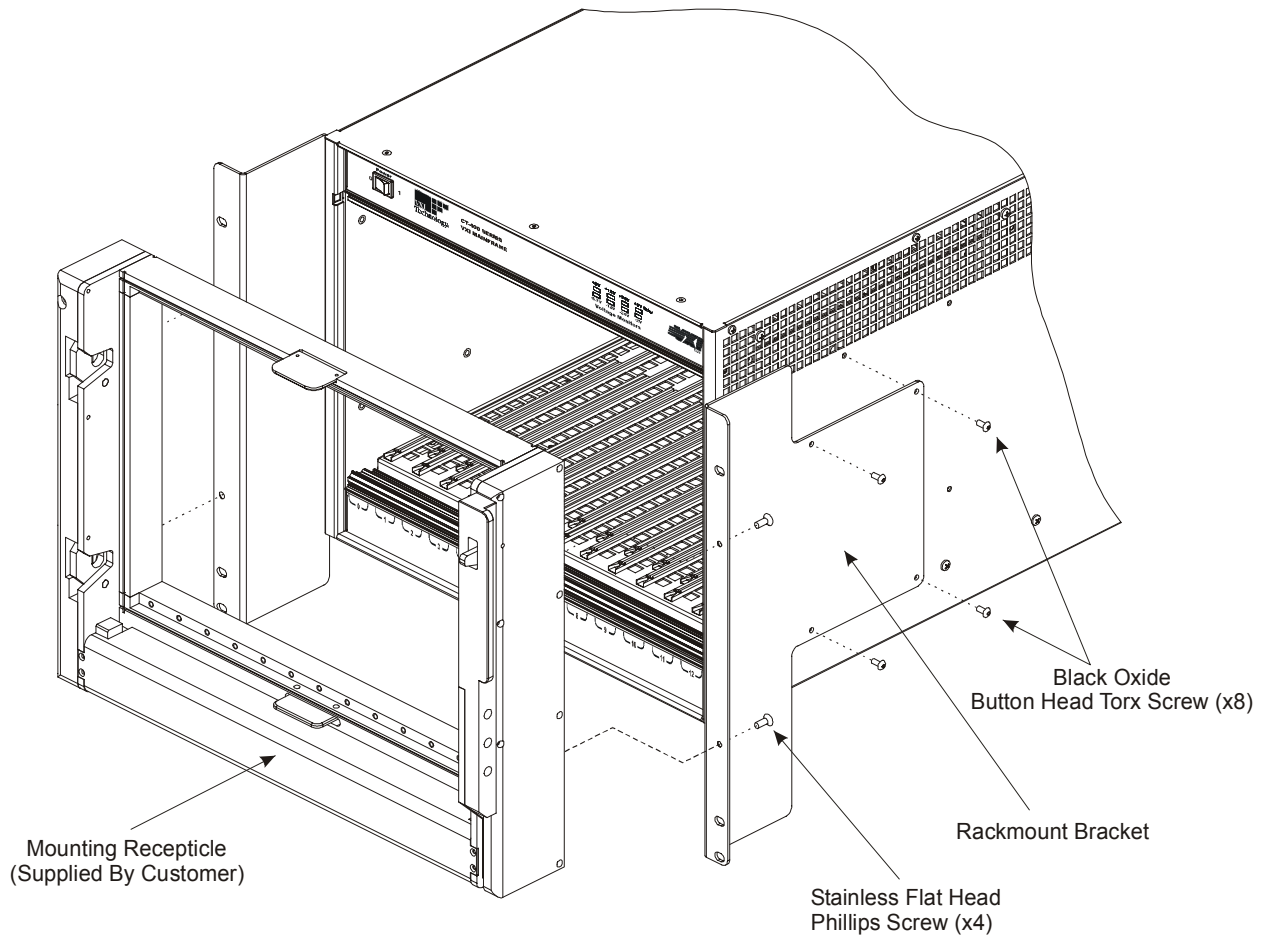

**FIGURE 2-4 VXIPLUG&PLAY RACK MOUNT INSTALLATION DIAGRAM**

## **OPTION 102 - RACK MOUNT SLIDES**

Rack mount slides allow the end user the ability to easily access the mainframe after it has been installed into an EIA rack. This option may be used in conjunction with either Option 100 or 101, or maybe installed and used independently. (Refer to the previous section for Option 100 and 101 installation instructions.)

### **REQUIRED TOOLS**

1. #2 Phillips Screwdriver

### **PARTS LIST**

<b>QTY</b>	<b>ITEM</b>	<b>VTI P/N</b>
1	Slide, Rack Mount, 24"	37-0127-024
1	Bracket, Slide, Rear, Use with 37-0127-024	37-0128-000
10	Screw, 8-32 x 3/4" Flat Head Phillips, 82 Deg, Stainless	37-0129-075
2	Spacer, Rack Slide	41-0220-000

### **ASSEMBLY PROCEDURE**

1. Lay the mainframe on a protected work surface on its long side with the voltage monitor LEDs of the mainframe facing front with the power switch toward the top.
2. Locate the rack slide spacers. Attach the spacers to the mainframe as shown in Figure 2-5 using the screws provided with the kit (5 screws per spacer). Note the positioning of the notch when installing the spacer.
3. Locate the 24" rack mount slides. Attach these slides to the spacer by sliding the groove of the rack mount slide over spacer installed onto the mainframe. The notch of the spacer should lock into the hole of the slide, securing the slide to the mainframe.

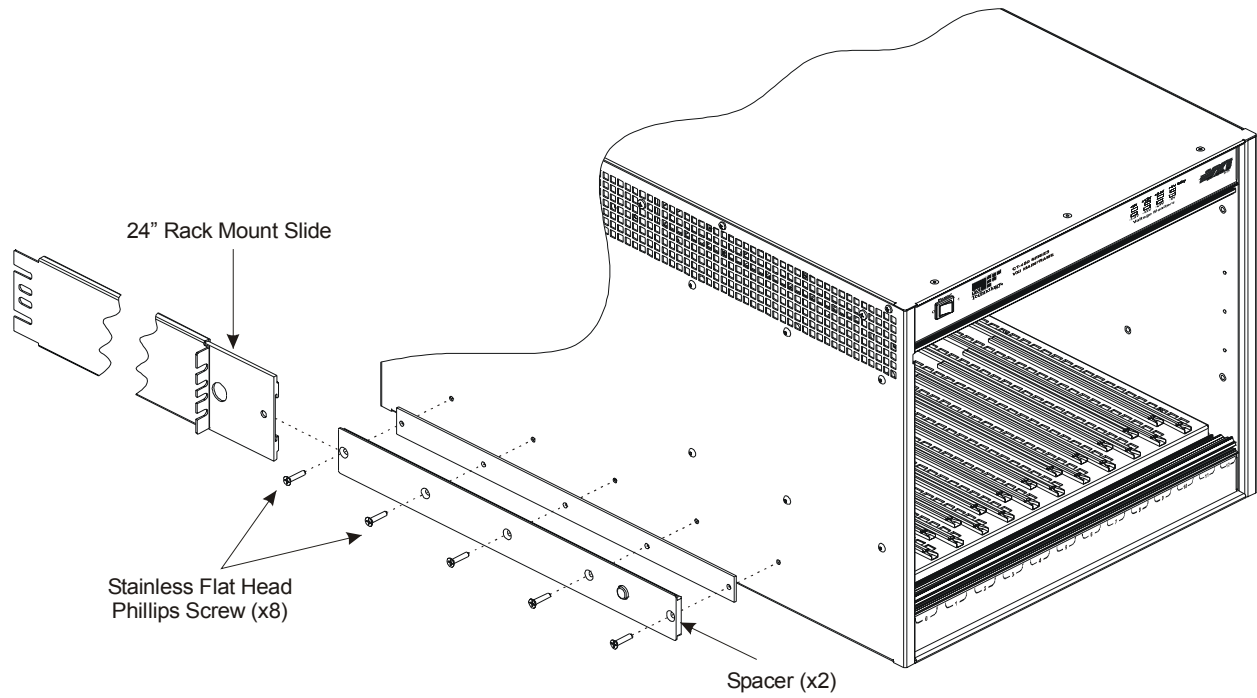

**FIGURE 2-5 RACK MOUNT SLIDE INSTALLATION DIAGRAM**

---

# ADDITIONAL RACK MOUNT OPTIONS

---

## OVERVIEW

This section contains the procedures for installing additional options for the CT-400. The available rack mounting options are:

### ***Option 103 - Transparent Front Door***

---

The transparent front door provides protection of instruments and cables while permitting the viewing of VXIbus instrument annunciators.

### ***Option 104 - Hinged Custom Front Panel***

---

The customizable front panel hinges down and mounts on the front of the CT-400. This option allows custom connectors and small interface adapters to be mounted directly on the front of the VXIbus mainframe, reducing cable lengths and improving signal integrity.

### ***Option 105/106 - 1U / 2U Cable Trays***

---

Cable trays are available in 1U and 2U depths that allow access between the front and rear of the mainframe and other instruments within the rack.



## **OPTION 103 - TRANSPARENT FRONT DOOR INSTALLATION PROCEDURE**

This kit requires Option 100 be installed prior to its installation. Refer to the previous section on Option 100 for installation instructions.

### **REQUIRED TOOLS**

1. #2 Phillips Screwdriver

### **PARTS LIST**

<b>QTY</b>	<b>ITEM</b>	<b>VTI P/N</b>
2	Screw, 8-32 x 3/8" Phillips, Sq Cone Sems Zinc	37-0073-037
8	Screw, 8-32 x 3/8" Flat Head Phillips, Zinc	37-0080-037
1	Flush Pull Latch, 2.0" Dia., Black Polycarbonate	37-0118-000
2	Hinge, Nylon Lift Off, Offset Knuckle, Black	37-0131-000
1	Latch Bracket, Front Door	41-0225-000
1	Front Door, Transparent Bronze	41-0226-000

### **ASSEMBLY PROCEDURE**

1. Lay the mainframe on a protected work surface on its long side with the voltage monitor LEDs of the mainframe facing front with the power switch toward the top.
2. Locate the nylon hinges. Separate the hinges into its male and female components. Attach the female component to the left rack mount flange using 8-32 x 3/8" flat head Phillips screws as illustrated in Figure 2-6. Note that the holes of the component are oriented in an upright position.
3. Take the male components and attach them to the transparent bronze door using the 8-32 x 3/8" flat head Phillips screws provided. Use Figure 2-6 for guidance in orienting this component.
4. Locate the pull latch. Seat the latch mechanism into the door on the same side as the hinges. Attach the cover of the latch using the screws provided with the latch.
5. Locate the latch bracket. Attach the bracket to the right rack mount flange using the Phillips screws indicated on the opposing page.
6. Reconnect the male and female components of the hinge.



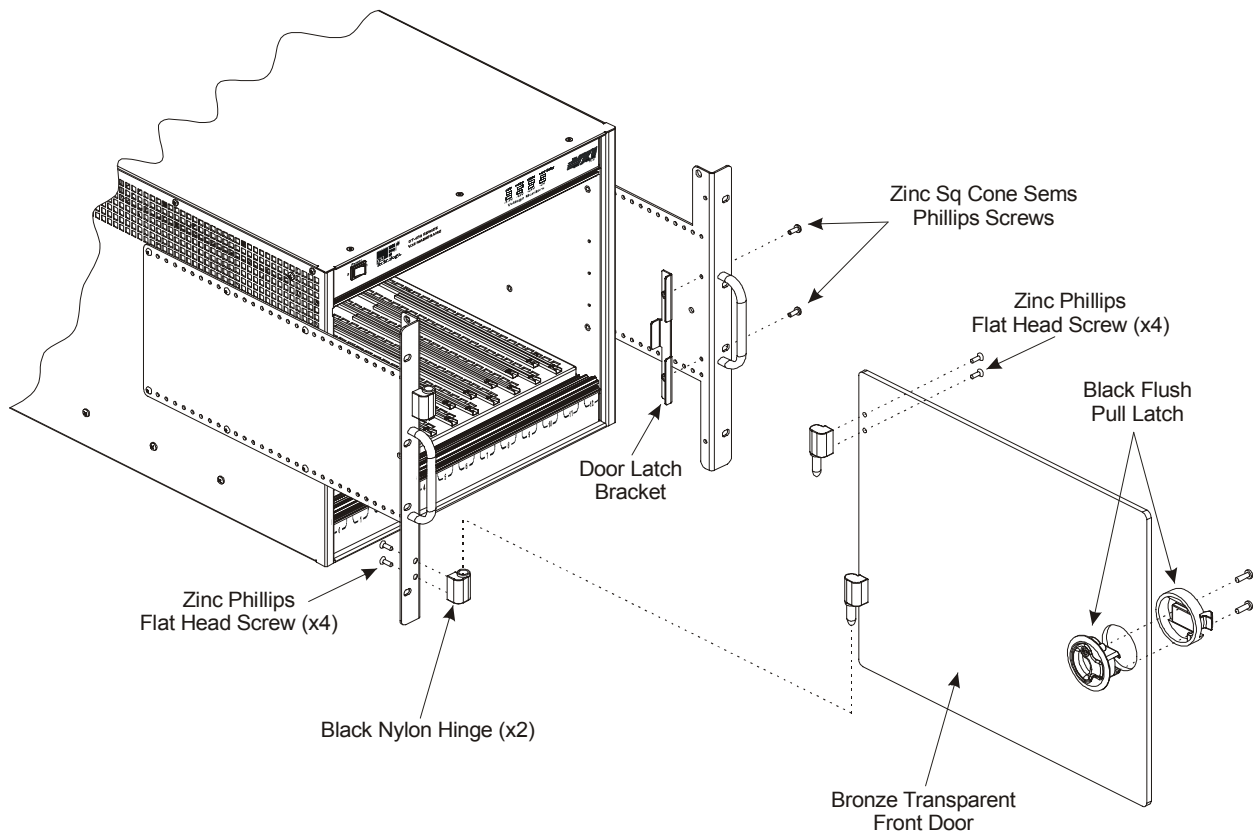

**FIGURE 2-6 TRANSPARENT DOOR INSTALLATION DIAGRAM**

## **OPTION 104 - HINGED CUSTOM FRONT PANEL INSTALLATION PROCEDURE**

This kit includes the hardware found in Option 100 as well as the hardware necessary to install the hinged custom front panel.

### **REQUIRED TOOLS**

1. #2 Phillips Screw Driver
2. T15 Torx screwdriver
3. 3/8" Open Ended Wrench

### **PARTS LIST**

<b>QTY</b>	<b>ITEM</b>	<b>VTI P/N</b>
2	Hinge, Adjustable Damping, Black	37-0066-000
4	Screw, 8-32 x 3/8" Flat Head Phillips, Zinc	37-0080-037
12	Screw, 8-32 x 5/8" Button Head Torx, Black Steel	37-0130-062
2	Handle, Chassis, 1 9/32" x 4", Black Aluminum	37-0134-000
1	Hinge, Support, Custom Door, Right Side, Nickel	37-0136-000
1	Hinge, Support, Custom Door, Left Side, Nickel	37-0136-001
1	Rack Mount Bracket, Standard, Left Side	41-0221-000
1	Rack Mount Bracket, Standard, Right Side	41-0221-001
1	Front Door, Application Specific	41-0229-000
1	Lower Support Bracket, App Spec Door	41-0230-000
1	Upper Support Bracket, App Spec Door	41-0231-000
4	Washer, Split Lock, 8-32 Zinc	37-0013-008
4	Nut, Hex, 8-32, Zinc/Steel	37-0030-832
2	Screw, 8-32 x 3/8" Pan Head Phillips, Steel/Zinc	37-0074-037
2	Washer, Shoulder, 8-32, Nylon	37-0145-008
2	Standoff, 3/8" Hex, M/FM x 0.25 Long, 10-32 M, 8-32 FM, SS	37-0146-000
12	Screw, 8-32 x 1/4", Truss Head Phillips, Blk Oxide	37-0038-025
8	Screw, 8-32 x 3/8" Pan Head Phillips, M/S, Blk Oxide	37-0079-037

### **ASSEMBLY PROCEDURE**

1. Lay the mainframe on a protected work surface on its long side with the voltage monitor LEDs of the mainframe facing front with the power switch toward the top.
2. Locate the right and left side rack mount brackets. Install the rack mount brackets using eight 8-32 x 5/8" button head Torx screws. Refer to Figure 2-7 for guidance. In order for the custom panel to utilize the support hinges, the mainframe must be recessed by at least 6.5 inches (16.51 cm).
3. Locate the handles for the rack mount brackets. Use the 8-32 x 3/8" Phillips screws to install these handles as shown in Figure 2-7.
4. Locate the upper and lower support brackets. Attach these brackets to the rack mount flanges above using the 8-32 x 1/4" black truss head Phillips screws.
5. Attach the standoffs to the rack mount brackets as indicated in Figure 2-7 below.

6. Locate support brackets. Attach the support brackets to the appropriate rack mount flange using an 8-32 x 3/8" pan head Phillips screw and a nylon washer.
7. Locate the adjustable hinges. Attach the hinges to the front door using 8-32 x 3/8" pan head Phillips screws. Attach the door to the lower support bracket using the same hardware.
8. Attach the door to the support hinges using a nylon washer and an 8-32 x 3/8" pan head Phillips screws.

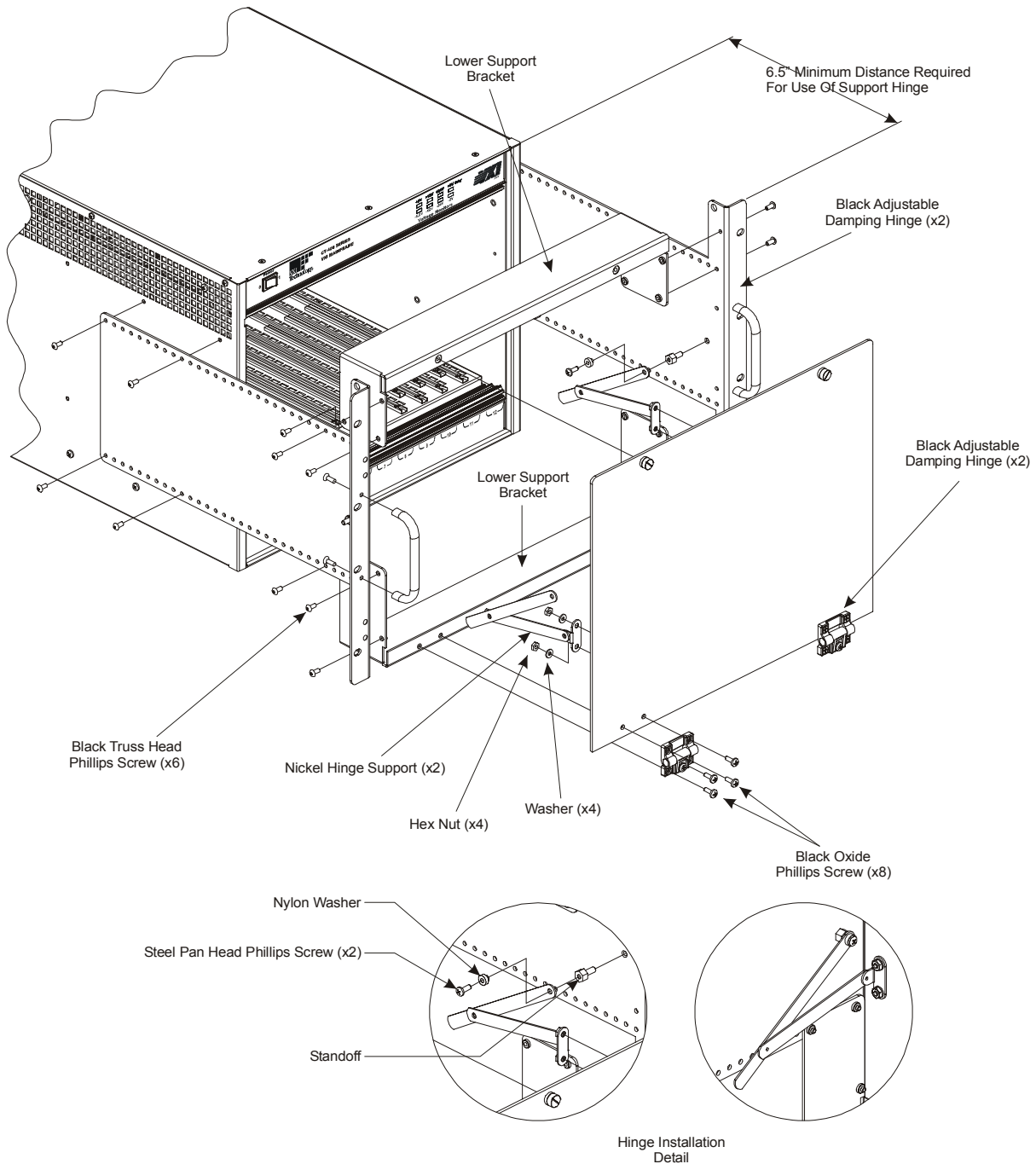

**FIGURE 2-7 CUSTOMIZABLE FRONT DOOR INSTALLATION DIAGRAM**

## **OPTION 105/106 - 1U/2U CABLE TRAYS INSTALLATION PROCEDURE**

The 1U/2U cable trays make organizing the cabling associated with the mainframe and modules more manageable. The cable tray is the same both the 1U and 2U version, with only the height of the rear panel differentiating between the two.

### **REQUIRED TOOLS**

1. #2 Phillips Screw Driver

### **PARTS LIST**

<b>QTY</b>	<b>ITEM</b>	<b>VTI P/N</b>
5	Screw, 6-32 x 3/8" Pan Head Ph, Sq Cone Sems Zinc	37-0028-037
1	Rear Panel, Wire Tray, User Modifiable, 1U	41-0227-000
	-or-	
	Rear Panel, Wire Tray, User Modifiable, 2U	41-0227-001
1	Cable Tray, 1U / 2U Deep	41-0228-000

### **ASSEMBLY PROCEDURE**

1. Lay the mainframe on a protected work surface on its long side with the voltage monitor LEDs of the mainframe facing front with the power switch toward the top.
2. Locate the cable tray. Attach the rear panel (either 1U or 2U) using the screws provided with kit. See Figure 2-8 for screw locations.
3. Locate the ten screws at the bottom of the side plates and remove. See Figure 2-8 for location.
4. Attach the cable tray to the mainframe using the screws removed in Step 3. This process is most easily accomplished with the mainframe oriented upside-down.

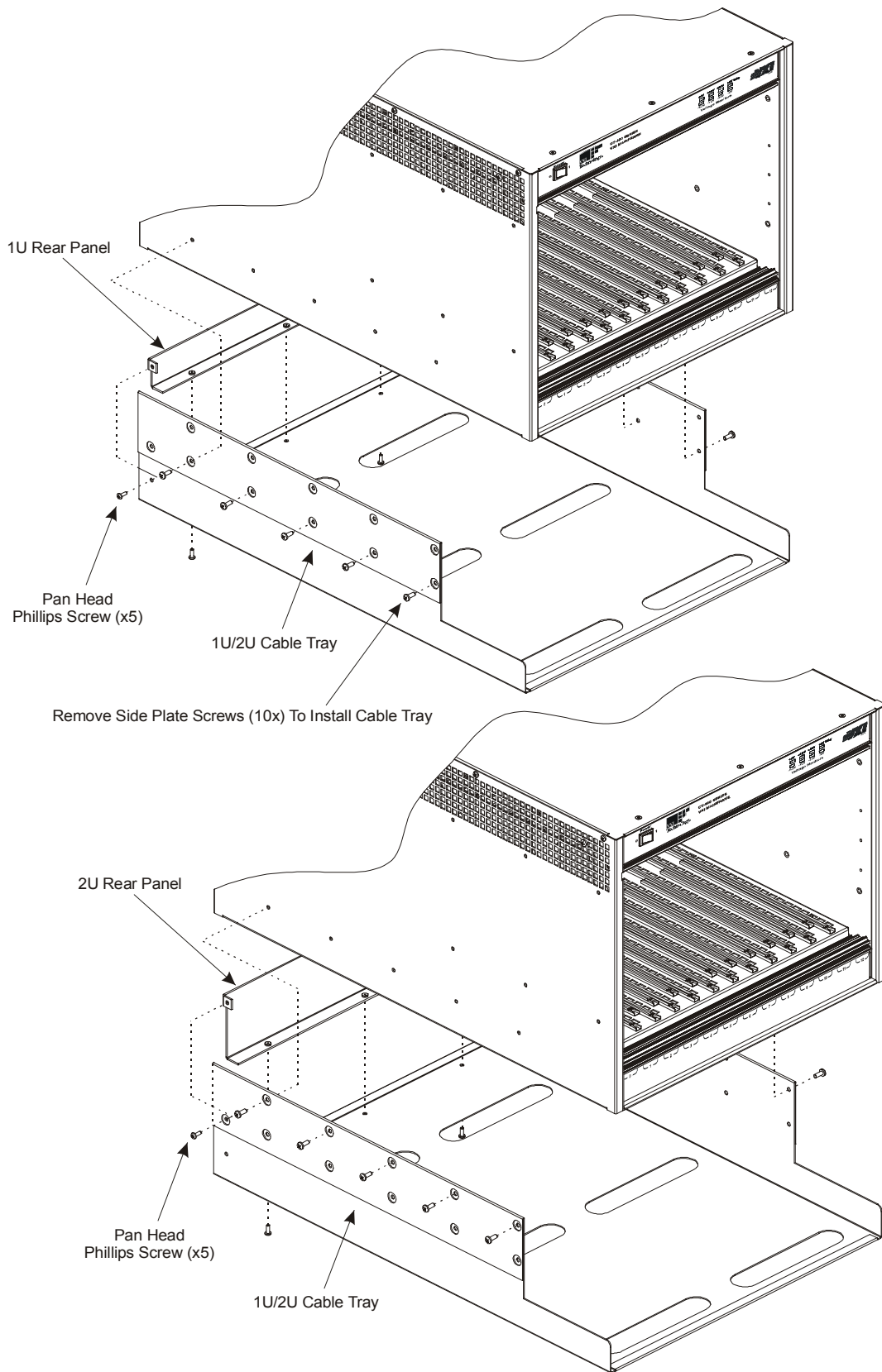

**FIGURE 2-8 1U (TOP) AND 2U (BOTTOM) CABLE TRAY INSTALLATION DIAGRAMS**

---

# INSTALLATION OF VXI MODULES

---

## OVERVIEW

After the successful installation of rack mount accessories, the chassis is ready for installation of the VXIbus base units (i.e. an SMP1100, SMP1200, etc.). It is recommended that the instruments be installed after rack mount accessories have been installed to avoid any unnecessary physical strains that may be incurred during the installation of the accessories. Whether single- or double-wide, the process of installation is simple.

## REQUIRED TOOLS

1. Phillips head screw driver

## INSTALLATION PROCEDURE

Install C-size modules directly into the mainframe as follows:

1. To prevent damage to the module, insure the mainframe is powered off.
2. Insert the module into the mainframe by aligning it with both the upper and lower card guide of the desired slot. The card guide for the module is the right, longer guide-pair of each guide set.
3. Gently push the module into the slot until it seats into the backplane connectors. The front panel of the module should be flush with mainframe.
4. Tighten the mounting screws at the top and bottom of the module.

---

## DISCONNECTING THE MAINFRAME

---

To disconnect the CT-400 from its installation, simply follow the instructions below:

1. Place the mainframe in standby by depressing the power switch.
2. Remove the power cord from the mainframe to ensure that no power is running to the mainframe.
3. Remove all cabling associated with the VXI modules installed in the CT-400.
4. If the chassis is rack mounted, remove the chassis from the rack by removing the screws that attach the mainframe to the rack.

Rack mount options can be removed from the mainframe at this time if desired.



**To avoid electrical shock, ensure power is removed from the mainframe before installing or uninstalling modules.**

**All modules are grounded through the mainframe backplane. To ensure a good ground connection, the module mounting screws must be secure.**

---





# SECTION 3

---

## OPERATION

---

### INTRODUCTION

There are no operating instructions required for the CT-400 VXibus mainframe. After the mainframe is installed, operation is completely transparent to the operator. Just plug in the instruments then power up the mainframe. The power supply lines and mainframe operation are monitored and displayed to provide user-feedback of correct operation.

## CT-400 MONITOR BOARD

The CT-400 Monitor board provides monitoring of the mainframe’s operation and environment. It provides the user with access to the seven VXIbus backplane voltages (to power external circuitry), access to the eight backplane TTL trigger lines (for input and output) and control over the unit’s cooling operation.

The cooling operation can be selected with the three-position fan speed switch located on the Monitor board. In the low-speed position, the fans are run at a low speed providing adequate cooling for most medium to low power modules. Running the fans at low speed will assure minimum audible noise from the mainframe as well as increasing the life of the fan. In the high-speed position, the fans are run at their maximum speed for maximum cooling. In the variable-speed setting, the factory default, the fan speed is adjusted by the power drawn from the power supply and the ambient temperature. The fan speed is equal to the low-speed setting when no power is drawn from the backplane and the ambient temperature is 25°C. As ambient temperature rises to 45°C, the fans are increased to the maximum speed in proportion to the temperature. In addition, as the backplane loading increases from 0 to 1000 W, the fan speed is increased from the low speed to the maximum speed. It should be noted that both these factors work together to set the fan speed.

The CT-400 Monitor board provides all seven VXIbus voltages for user use. Each voltage is available on connector J211 and is protected by a self-healing fuse rated for 1.0 A per voltage. In the event that the current rating is exceeded or the line is shorted, the fuse will open and remain open so long as the fault condition is present. Once the fault is removed, the fuse will restore power to the connector in a few seconds.

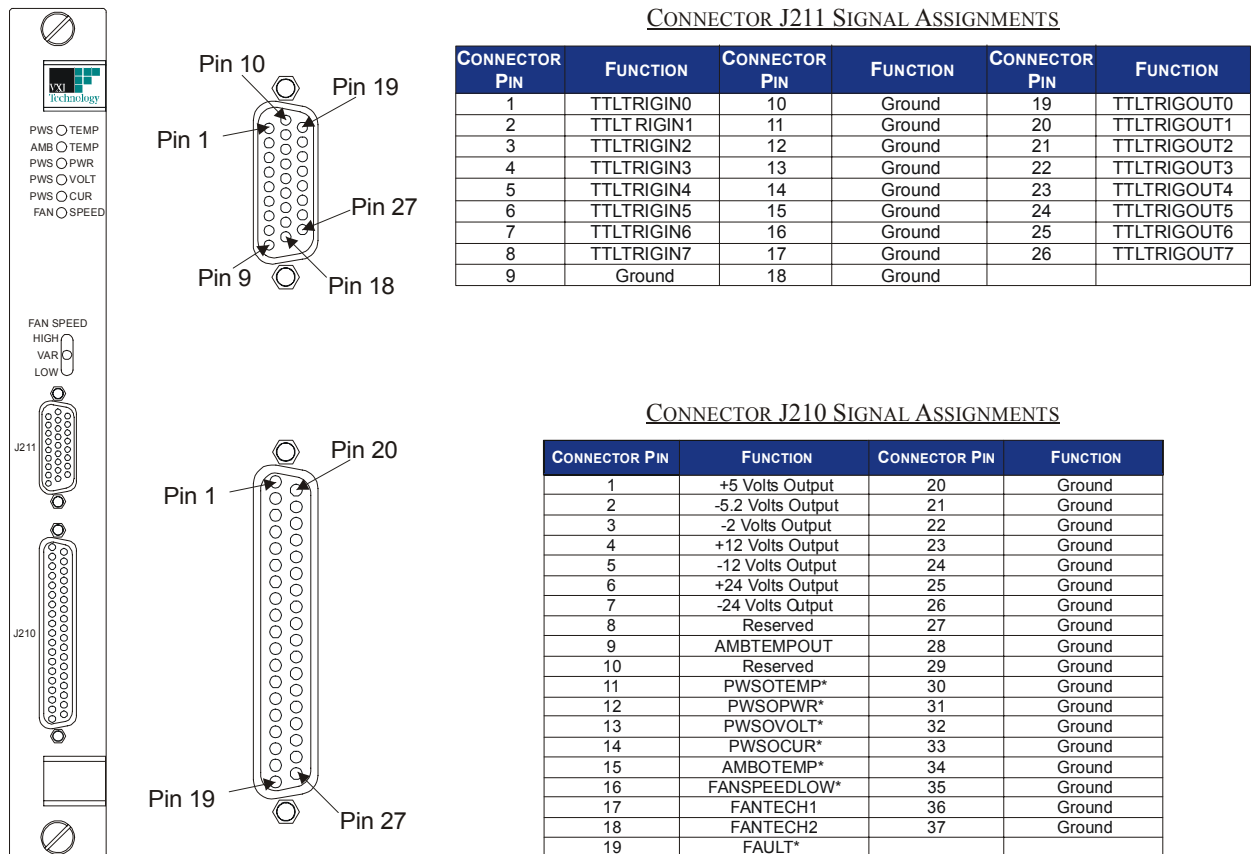
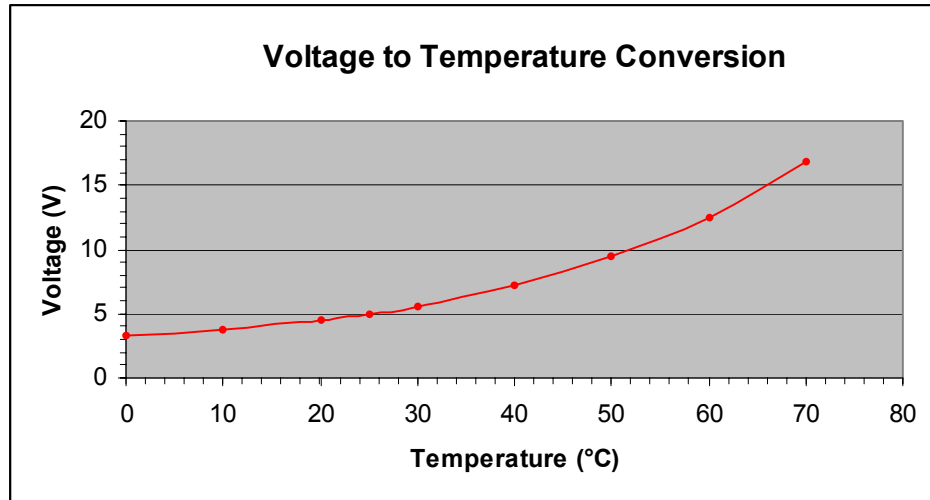

**FIGURE 4-1 MONITOR BOARD FRONT PANEL AND CONNECTOR PIN LOCATIONS & ASSIGNMENTS**

## CT-400 MONITOR BOARD - SIGNALS

### Connector J210

**AMBTEMPOUT** – Analog output reflecting the temperature of the air entering the mainframe. This is a non-linearized signal. See Figure 4-2 for a voltage to temperature conversion.



Ambient Temp	AMBTEMPOUT	Ambient Temp	AMBTEMPOUT
0°C	3.27 V	40°C	7.19 V
10°C	3.76 V	50°C	9.44 V
20°C	4.50 V	60°C	12.55 V
25°C	5.00 V	70°C	16.77 V
30°C	5.60 V		

**FIGURE 4-2 TEMPERATURE / VOLTAGE CONVERSION**

**PWSOTEMP\*** - This low true open collector output signals a power supply over-temperature condition. This fault condition occurs when the maximum internal temperature of the power supply is exceeded. This signal is pulled up to +5 volts with a 4.7k resistor internally.

**PWSOPWR\*** - This low true open collector output signals a power supply over-power condition. This fault will occur when more power is demanded from the power supply than it can provide. This signal is pulled up to +5 volts with a 4.7k resistor internally.

**PWSOVOLT\*** - This low true open collector output signals a power supply over-voltage condition. This fault occurs when one of the voltages produced by the power supply exceeds its maximum value. This signal is pulled up to +5 volts with a 4.7k resistor internally.

**PWSOCUR\*** - This low true open collector output signals a power supply over-current condition. This fault occurs when the maximum current of a voltage is exceeded. This signal is pulled up to +5 volts with a 4.7k resistor internally.

**AMBOTEMP\*** - This low true open collector output signals a power supply over-temperature condition. This fault occurs when the ambient air temperature exceeds 55°C. This signal is pulled up to +5 volts with a 4.7k resistor internally.

**FANSPEEDLOW\*** - This low true open collector output signals a power supply over-temperature condition. This fault occurs when either of the two fans supplying air to the VXI instruments speed drops below 1000 RPM. This signal is pulled up to +5 volts with a 4.7k resistor internally.

**FANTACH1** - This is a TTL compatible pulse output, whose period is a function of fan number 1 supplying air to the VXI instruments. This signal provides 5 positive edges per revolution of the fan. This tachometer output is derived from the current pulses produced when the fans turn; therefore, when the fan speed is changed abruptly (such as when the fan speed switch is changed) the output may become unstable momentarily.

**FANTECH2** - This is a TTL compatible pulse output, whose period is a function of fan number 2 supplying air to the VXI instruments. This signal provides 5 positive edges per revolution of the fan. This tachometer output is derived from the current pulses produced when the fans turn; therefore, when the fan speed is changed abruptly (such as when the fan speed switch is changed) the output may become unstable momentarily.

**FAULT\*** - This low true open collector output is the logical OR of all the other fault signals. This signal is pulled up to +5 volts with a 4.7k resistor internally.

### ***Connector J211***

---

**TTLTRIGIN<sub>x</sub>** - TTLTRIGIN0 through TTLTRIGIN7 provide input access to the eight VXIbus TTLTRIGGER bus lines. Each input is terminated with a 330  $\Omega$  resistor to +5 volts and a 470  $\Omega$  resistor to ground and is compatible with 74F series TTL logic input levels. Each signal is buffered and drives its respective TTL trigger line with an open collector driver.

**TTLTRIGOUT<sub>x</sub>** - TTLTRIGOUT0 through TTLTRIGOUT7 provide output access to the eight VXIbus TTL trigger bus lines. Each bus signal is buffered and is compatible with 74F series TTL logic output levels.

# SECTION 4

---

## SERVICE INFORMATION

---

### INTRODUCTION

The CT-400 should operate without the need for service, except for regular cleaning of the air filter elements. The cleaning schedule is dependant upon the amount of dust in the air, how many hours the unit is operated and how much airflow is required to adequately cool the installed instruments.

<b>Note</b>	Service should only be performed by qualified personnel.
-------------	--

## CLEANING THE AIR FILTERS

Two air filters are present on the CT-400: a module fan filter and a power supply fan filter. Keeping these filters clean is important in maintaining an adequate air flow through the mainframe and over the power supply. The air filters can be cleaned in the following manner.

### *Cleaning the Power Supply Fan Filter*

---

1. Power off the mainframe and remove the power cord.
2. Locate the metal cover plate to the right of the power cord connector and fuse.
3. Loosen the two thumbscrews holding the cover plate and remove it.
4. Slide the power supply filter element out of the slot underneath the cover plate.
5. Blow the dust and dirt out of the air filter element using compressed air or, optionally, use water and a mild soap.
6. If water and soap are used, make sure to rinse the element of all soap and allow it to dry before reinstalling it in the mainframe.
7. Reinstall the air filter element and the cover plate and tighten the thumbscrews.

***Cleaning the Module Fan Filter***

---

1. Power off the mainframe and remove the power cord.
2. Locate the metal air filter cover at the bottom half of the mainframe.
3. Remove the four screws holding it in place and remove the cover and the filter element.
4. Blow the dust and dirt out of the air filter element using compressed air or, optionally, use water and a mild soap.
5. If water and soap is used, make sure to rinse the element of all soap and allow it to dry before reinstalling it in the mainframe.
6. Reinstall the air filter element and cover and reinstall the screws.

## POWER SUPPLY REPLACEMENT PROCEDURE

In the event that the cooling fans or power supply must be replaced, they are contained in a single, easy to remove module. Replacement of the power supply can be accomplished as follows:

1. Power off the mainframe and remove the power cord.
2. Locate four thumbscrews on the rear of the mainframe and loosen all four.
3. Locate two handles on the power supply and firmly pull the module straight back and remove.
4. Locate the replacement power supply module and install it into the mainframe.
5. Seat the power supply module firmly in place and finger tighten the four thumbscrews.
6. Verify that the front panel power switch is in the off position and reattach the power cord.



**Before removing the power supply unit, insure that the mainframe is in a secure location and will not tip. *Service should only be performed by trained personnel.***

---



# SECTION 5

## DOCUMENTATION

### INTRODUCTION

This section contains drawings and parts lists for the installation options of the CT-400 Mainframe. The documents are in order by VTI part number:

**TABLE 5-1 DOCUMENT LISTING**

VTI P/N	TYPE	DESCRIPTION
41-0221-000	DWG.	RACK MOUNT BRACKET, STANDARD, LEFT SIDE, CT-400
41-0221-001	DWG.	RACK MOUNT BRACKET, STANDARD, RIGHT SIDE, CT-400
41-0223-000	DWG.	RACK MOUNT BRACKET, PLUG&PLAY, LEFT SIDE, CT-400
41-0223-001	DWG.	RACK MOUNT BRACKET, PLUG&PLAY, RIGHT SIDE, CT-400
70-0103-000	PARTLIST	FINAL ASSY, ADJUSTABLE RACK MOUNT KIT, CT-400 OPTION 100
70-0104-000	PARTLIST	FINAL ASSY, PLUG & PLAY RACK MOUNT KIT, CT-400 OPTION 101
70-0105-000	PARTLIST	FINAL ASSY, RACK SLIDE KIT, CT-400 OPTION 102
70-0106-000	PARTLIST	FINAL ASSY, TRANSPARENT FRONT DOOR KIT, CT-400 OPTION 103
70-0108-000	PARTLIST	FINAL ASSY, 1U CABLE TRAY KIT, CT-400 OPTION 105
70-0108-001	PARTLIST	FINAL ASSY, 2U CABLE TRAY KIT, CT-400 OPTION 106

**Note** To view full-scale drawings, see the Acrobat file on the CD included with this manual.

---

# INDEX

---

**A**

air filters..... 28, 53, 54  
     cleaning ..... 54, 55  
 airflow..... 14, 18, 28, 53

**B**

backplane..... 14, 46  
 backplane voltages..... 17, 50  
 base unit installation ..... 46  
 bus grant ..... 14  
 bus lines ..... 52

**C**

card guide ..... 46  
 card shield..... 29  
 cooling ..... 29  
 cooling operation ..... 50

**D**

dimintions ..... 20  
 disconnecting the mainframe ..... 47  
 dynamic current ..... 19

**E**

earth ground..... 28

**F**

fan speed..... 50  
 front panel..... 14  
 fuse ..... 19  
 fuse rating ..... 27

**G**

grounding..... 28

**L**

line frequencies..... 14  
 line power ..... 27

**M**

mainframe features ..... 15  
 Monitor / Control Connector ..... 17  
 monitor board ..... 50  
 MTBF ..... 18  
 MTTR..... 18

**O**

operation ..... 15, 50  
 options ..... 21  
 over-current condition ..... 51  
 over-power condition ..... 51  
 over-temperature condition..... 51, 52  
 over-voltage condition ..... 51

**P**

peak current..... 19  
 power supply ..... 14  
     replacement..... 56  
 power supply lines ..... 49

**R**

rack mount..... 32

**S**

signals ..... 17  
 specifications..... 18, 19, 21  
     cooling ..... 18  
     environmental ..... 18  
     general ..... 18  
     power ..... 19  
 supply over-temperature condition..... 51

**T**

tachometer output..... 52  
 temperature..... 51  
 TTLTRIGGER line ..... 52

**V**

voltage..... 19  
 VXIbus ..... 14, 50, 52